



Attention to function & form

Elegant profile.

Optional Sun and Wind Sensor

Optional Remote control

The HAROL PR Series is a compact and reliable Folding Arm Awning designed, engineered and manufactured to ensure years of trouble free operation.

The HAROL PR220 has an aluminium extruded hood with strong cast aluminium end covers providing protection for the fabric.

The Arms: Extruded powder coated aluminium arms.

The Hinges: High pressure cast aluminium alloy. Hinge on durable slide bearings of toughened bronze with a PTFE sliding layer. The most heavily loaded parts are thermally treated..

Springs and Steel cables: Zinc plated high quality spring steel. Grease impregnated Zinc plated steel cables ensure an even division of power.

The Shoulder: Extruded powder coated aluminium components. Angle range from 10° to 45°. Design ensures against flapping and dropping of arms.

Sizes:
 Maximum- 6 metre in one part with two arms.
 - 7 metre in one part with three arms.
 - 12 metre in 2 parts with four arms.

Quality: 5 year Guarantee. You can therefore expect that only the best materials were used and a high level of importance placed on providing the perfect finish.

Operation: The PR Series can be equipped with electrical operation, using a tubular motor. For the ultimate in comfort an automatic wind-sun sensor regulates the awning automatically, depending on the light intensity and the wind speed. Manual operation using a crank and gearbox is also available.

PR220

FOLDING ARM AWNING



The HAROL PR220 has an aluminium extruded hood with strong cast aluminium end covers providing protection for the fabric.

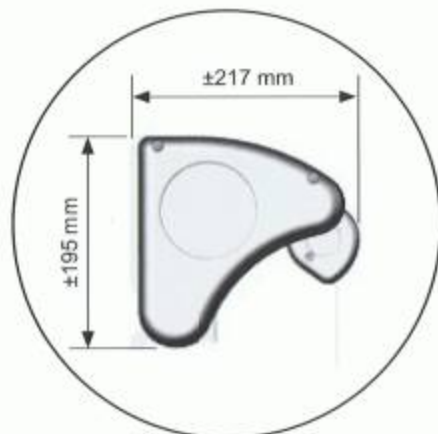

Profile dimensions



When extended the strong spring assembly in the arms ensures maximum fabric tension is maintained.



The covers are made of strong cast aluminium and the rounded extension pole is small and compact.

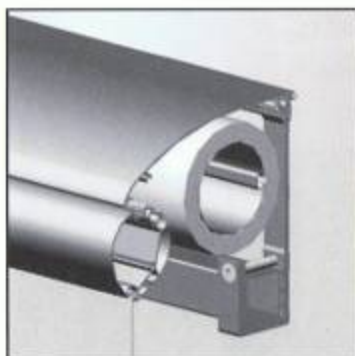

The fabric is protected with an aluminium powder coated extruded cover.

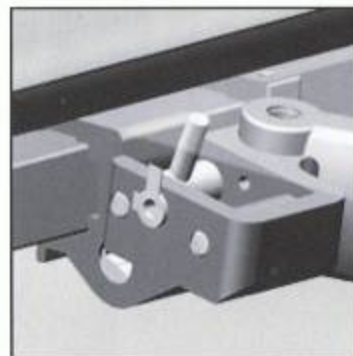

The solid angle adjustment shoulders ensures the gradient of the awning is maintained over the extension.



GOODEARL FABRIC SYSTEMS Pty Ltd

ABN 69 480 308 940 Established 1886

Phone: 02 9669 2311 Fax: 02 9667 3450

Email: gfs@fabricsystems.com.au

Web: www.fabricsystems.com.au

This leaflet can be downloaded from the website.

